

Vigor2710 Series ADSL2/2+ Firewall Router Quick Start Guide

Version: 3.0

Firmware Version: V3.6.3

Date: 12/12/2012

Copyright Information

Copyright Declarations

Copyright 2012 All rights reserved. This publication contains information that is protected by copyright. No part may be reproduced, transmitted, transcribed, stored in a retrieval system, or translated into any language without written permission from the copyright holders.

Trademarks

The following trademarks are used in this document:

- Microsoft is a registered trademark of Microsoft Corp.
- Windows, Windows 95, 98, Me, NT, 2000, XP, Vista and Explorer are trademarks of Microsoft Corp.
- Apple and Mac OS are registered trademarks of Apple Inc.
- Other products may be trademarks or registered trademarks of their respective manufacturers.

Safety Instructions and Approval

Safety Instructions

- Read the installation guide thoroughly before you set up the router.
- The router is a complicated electronic unit that may be repaired only by authorized and qualified personnel. Do not try to open or repair the router yourself.
- Do not place the router in a damp or humid place, e.g. a bathroom.
- Do not stack the routers.
- The router should be used in a sheltered area, within a temperature range of +5 to +40 Celsius.
- Do not expose the router to direct sunlight or other heat sources. The housing and electronic components may be damaged by direct sunlight or heat sources.
- Do not deploy the cable for LAN connection outdoor to prevent electronic shock hazards.
- Keep the package out of reach of children.
- When you want to dispose of the router, please follow local regulations on conservation of the environment.

Warranty

We warrant to the original end user (purchaser) that the router will be free from any defects in workmanship or materials for a period of two (2) years from the date of purchase from the dealer. Please keep your purchase receipt in a safe place as it serves as proof of date of purchase. During the warranty period, and upon proof of purchase, should the product have indications of failure due to faulty workmanship and/or materials, we will, at our discretion, repair or replace the defective products or components, without charge for either parts or labor, to whatever extent we deem necessary to restore the product to proper operating condition. Any replacement will consist of a new or re-manufactured functionally equivalent product of equal value, and will be offered solely at our discretion. This warranty will not apply if the product is modified, misused, tampered with, damaged by an act of God, or subjected to abnormal working conditions. The warranty does not cover the bundled or licensed software of other vendors. Defects which do not significantly affect the usability of the product will not be covered by the warranty. We reserve the right to revise the manual and online documentation and to make changes from time to time in the contents hereof without obligation to notify any person of such revision or changes.

Be a Registered Owner

Web registration is preferred. You can register your Vigor router via <http://www.draytek.com>.

Firmware & Tools Updates

Due to the continuous evolution of DrayTek technology, all routers will be regularly upgraded. Please consult the DrayTek web site for more information on newest firmware, tools and documents.

<http://www.draytek.com>

European Community Declarations

Manufacturer: DrayTek Corp.
Address: No. 26, Fu Shing Road, HuKou Township, HsinChu Industrial Park, Hsin-Chu, Taiwan
303
Product: Vigor2710 Series Router

DrayTek Corp. declares that Vigor2710 Series of routers are in compliance with the following essential requirements and other relevant provisions of R&TTE Directive 1999/5/EEC.

The product conforms to the requirements of Electro-Magnetic Compatibility (EMC) Directive 2004/108/EC by complying with the requirements set forth in EN55022/Class B and EN55024/Class B.

The product conforms to the requirements of Low Voltage (LVD) Directive 2006/95/EC by complying with the requirements set forth in EN60950-1.

Regulatory Information

Federal Communication Commission Interference Statement

This equipment has been tested and found to comply with the limits for a Class B digital device, pursuant to Part 15 of the FCC Rules. These limits are designed to provide reasonable protection against harmful interference in a residential installation. This equipment generates, uses and can radiate radio frequency energy and, if not installed and used in accordance with the instructions, may cause harmful interference to radio communications. However, there is no guarantee that interference will not occur in a particular installation. If this equipment does cause harmful interference to radio or television reception, which can be determined by turning the equipment off and on, the user is encouraged to try to correct the interference by one of the following measures:

- Reorient or relocate the receiving antenna.
- Increase the separation between the equipment and receiver.
- Connect the equipment into an outlet on a circuit different from that to which the receiver is connected.
- Consult the dealer or an experienced radio/TV technician for help.

This device complies with Part 15 of the FCC Rules. Operation is subject to the following two conditions:

- (1) This device may not cause harmful interference, and
- (2) This device may accept any interference received, including interference that may cause undesired operation.

Please visit <http://www.draytek.com/user/SupportDLRTTECE.php>



This product is designed for DSL, POTS and 2.4GHz WLAN network throughout the EC region and Switzerland with restrictions in France. Please see the user manual for the applicable networks on your product.

Table of Contents

1. Introduction.....	1
1.1 Panel Explanation	2
1.1.1 For Vigor2710	2
1.1.2 For Vigor2710n	4
1.1.3 For Vigor2710Vn	6
1.1.4 For Vigor2710VDn	8
1.2 Package Content.....	10
2. Installing Your Router.....	11
2.1 Hardware Installation.....	11
Stand Installation.....	13
2.2 Printer Installation.....	14
3. Configuring Web Pages	19
3.1 Accessing Web Page	19
3.2 Basic Configuration	20
3.3 Wireless Configuration	23
3.3.1 Using WPS.....	23
3.3.2 DECT Phone Connection (for VDn model only)	26
4. Trouble Shooting	29
4.1 Checking If the Hardware Status Is OK or Not.....	29
4.2 Checking If the Network Connection Settings on Your Computer Is OK or Not	30
4.3 Pinging the Router from Your Computer	32
4.4 Checking If the ISP Settings are OK or Not	33
4.5 Problems for 3G Network Connection.....	34
4.6 Backing to Factory Default Setting If Necessary.....	35
4.7 Contacting Your Dealer	36

1. Introduction

The Vigor2710 series features advanced bandwidth control mechanism such as IP-layer QoS, NAT Session Limitation, Bandwidth Borrowed, etc., to allow easy, flexible, reliable access control and bandwidth management.

The SPI (Stateful Packet Inspection) firewall uses object-based design to make settings of firewall policies easy. The CSM (Content Security Management) feature allows more precise and efficient access control for URL/Web Content Filtering, IM (Instant Messenger) and P2P (Peer to Peer) applications.

Vigor2710 supports up to 2 VPN tunnels using advanced protocols such as IPSec/PPTP/L2TP/L2TP over IPSec with AES/DES/3DES for encryption and MD5/SHA-1 for authentication.

Vigor2710 'n' models comply with 802.11n Draft-n standards. They support WEP/WPA/WPA2 encryption and MAC Address Control, Wireless LAN Isolation. The Wireless Rate Control function can adjust the data rate of each wireless station (client).

Vigor2710 'V' models provide two analogue phone connectors and one line port. It supports multiple SIP registrars with high flexible configuration and call handing options.

Vigor2710VDn supports the DECT function compliant with DECT GAP/CAT-iq. It allows users to dial VoIP call, PSTN call, and Internet call through DECT phone set registered in router.

In addition, Vigor2710 series supports USB interface for connecting USB printer to share printer or USB storage device for sharing files. Vigor2710 series provides two-level management to simplify the configuration of network connection. The user operation allows user accessing into WEB interface via simple configuration. However, if users want to have advanced configurations, they can access into WEB interface through administration operation.

1.1 Panel Explanation

1.1.1 For Vigor2710

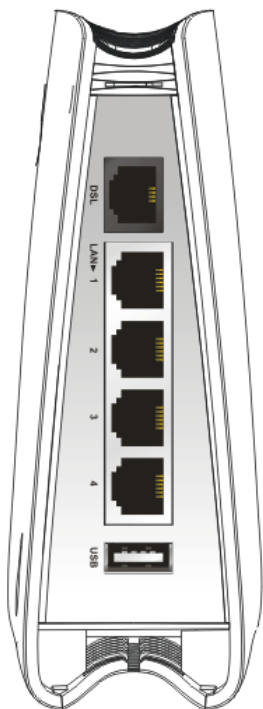
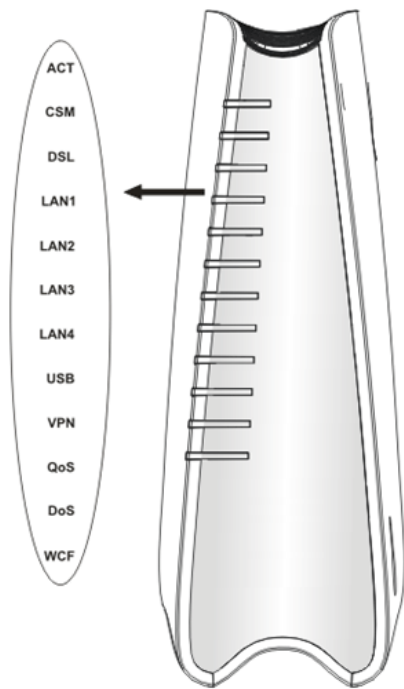

LED	Status	Explanation
ACT (Activity)	Blinking	The router is powered on and running normally.
	Off	The router is powered off.
CSM	On	The profile(s) of CSM (Content Security Management) for IM/P2P, URL/Web Content Filter application can be enabled from Firewall >>General Setup . (Such profile must be established under CSM menu).
	On	The router is ready to access Internet through DSL link.
DSL	Blinking	Slowly: The modem is ready. Quickly: The connection is training.
	On	The port is connected.
LAN 1/2/3/4	Off	The port is disconnected.
	Blinking	The data is transmitting.
USB	On	A USB device is connected and active.
	Blinking	The data is transmitting.
VPN	On	The VPN tunnel is active.
QoS	On	The QoS function is active.
DoS	On	The DoS/DDoS function is active.
	Blinking	It will blink while detecting an attack.
WCF	On	The profile(s) of CSM (Content Security Management) for Web Content Filter application can be enabled from Firewall >>General Setup . (Such profile must be established under CSM menu).

Interface	Description
DSL	Connector for accessing the Internet through ADSL2/2+.
LAN (1-4)	Connectors for local networked devices.
USB	Connector for USB storage device (Pen Driver/Mobile HD) or printer.

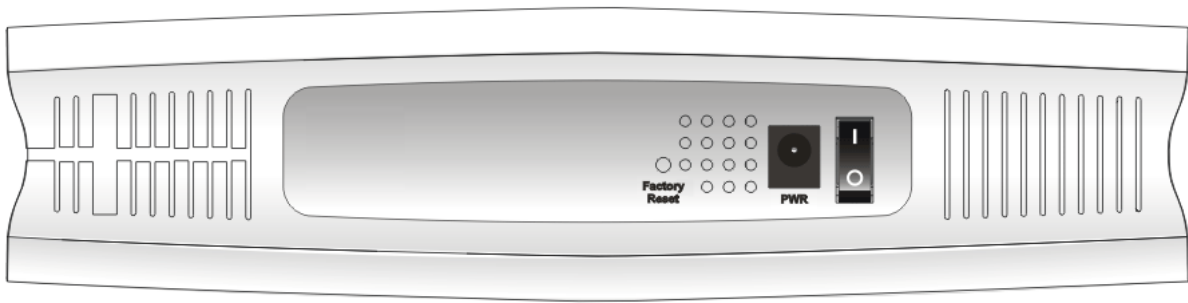

Interface	Description
Factory Reset	Restore the default settings. Usage: Turn on the router (ACT LED is blinking). Press the hole and keep for more than 5 seconds. When you see the ACT LED begins to blink rapidly than usual, release the button. Then the router will restart with the factory default configuration.
PWR	Connector for a power adapter.
ON/OFF	Power Switch.

1.1.2 For Vigor2710n

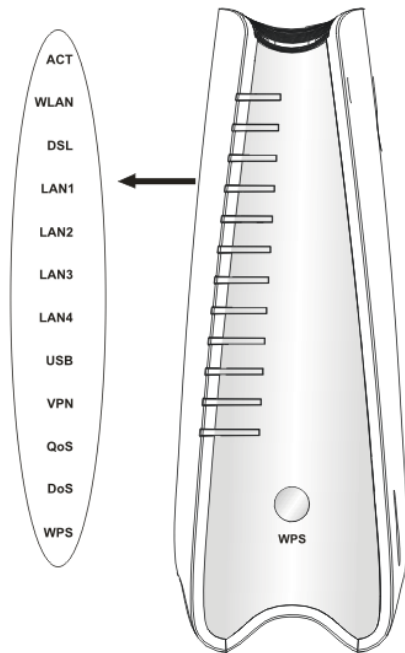

LED	Status	Explanation
ACT (Activity)	Blinking	The router is powered on and running normally.
	Off	The router is powered off.
WLAN	On	Wireless access point is ready.
	Blinking	It will blink while wireless traffic goes through.
DSL	On	The router is ready to access Internet through DSL link.
	Blinking	Slowly: The modem is ready. Quickly: The connection is training.
LAN 1/2/3/4	On	The port is connected.
	Off	The port is disconnected.
	Blinking	The data is transmitting.
USB	On	A USB device is connected and active.
	Blinking	The data is transmitting.
VPN	On	The VPN tunnel is active.
QoS	On	The QoS function is active.
DoS	On	The DoS/DDoS function is active.
	Blinking	It will blink while detecting an attack.
WPS	On	The WPS is on.
	Off	The WPS is off.
	Blinking	Waiting for wireless client sending requests for connection about two minutes.
WPS Button	On	Press this button for 2 seconds to wait for client device making network connection through WPS. When the LED lights up, the WPS will be on.
	Off	The WPS is off.
	Blinking	Waiting for wireless client sending requests for connection about 2 minutes.

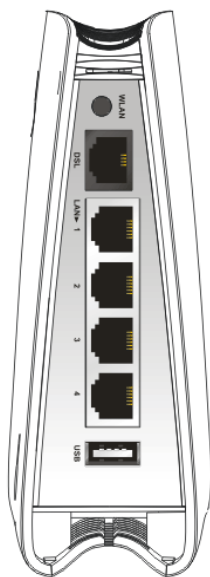

Interface	Description
WLAN	Press the button once to enable (WLAN LED on) or disable (WLAN LED off) wireless connection.
DSL	Connector for accessing the Internet through ADSL2/2+.
LAN (1-4)	Connectors for local networked devices.
USB	Connector for USB storage (Pen Driver /Mobile HD) or printer.

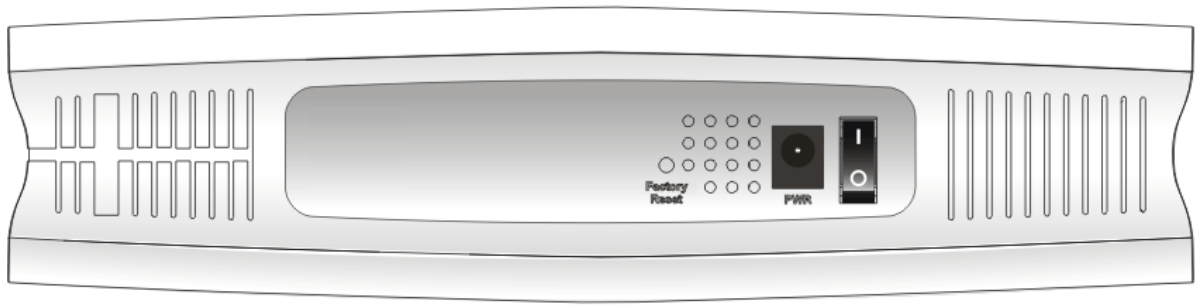

Interface	Description
Factory Reset	Restore the default settings. Usage: Turn on the router (ACT LED is blinking). Press the hole and keep for more than 5 seconds. When you see the ACT LED begins to blink rapidly than usual, release the button. Then the router will restart with the factory default configuration.
PWR	Connector for a power adapter.
ON/OFF	Power Switch.

1.1.3 For Vigor2710Vn

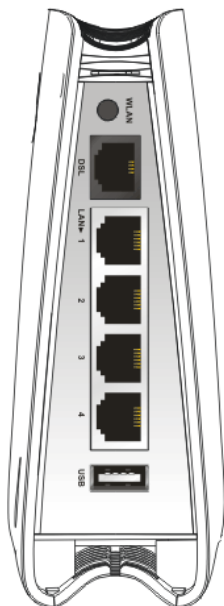
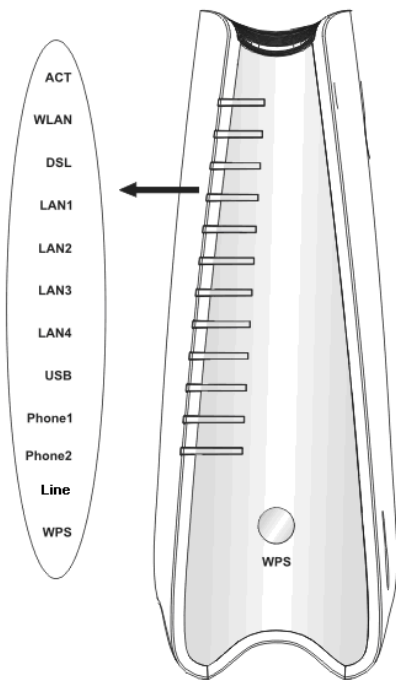

LED	Status	Explanation
ACT (Activity)	Blinking	The router is powered on and running normally.
	Off	The router is powered off.
WLAN	On	Wireless access point is ready.
	Blinking	It will blink while wireless traffic goes through.
DSL	On	The router is ready to access Internet through DSL link.
	Blinking	Slowly: The modem is ready. Quickly: The connection is training.
LAN 1/2/3/4	On	The port is connected.
	Off	The port is disconnected.
	Blinking	The data is transmitting.
USB	On	A USB device is connected and active.
	Blinking	The data is transmitting.
Phone1/ Phone2	On	The phone connected to this port is off-hook.
	Off	The phone connected to this port is on-hook.
	Blinking	A phone call comes.
Line	On	A PSTN phone call comes (in and out). However, when the phone call is disconnected, the LED will be off about six seconds later.
	Off	There is no PSTN phone call.
WPS	On	The WPS is on.
	Off	The WPS is off.
	Blinking	Waiting for wireless client sending requests for connection about two minutes.
WPS Button	On	Press this button for 2 seconds to wait for client device making network connection through WPS. When the LED lights up, the WPS will be on.
	Off	The WPS is off.
	Blinking	Waiting for wireless client sending requests for connection about 2 minutes.

Interface	Description
WLAN	Press the button once to enable (WLAN LED on) or disable (WLAN LED off) wireless connection.
DSL	Connector for accessing the Internet through ADSL2/2+.
LAN (1-4)	Connectors for local networked devices.
USB	Connector for USB storage (Pen Driver/Mobile HD) or printer.

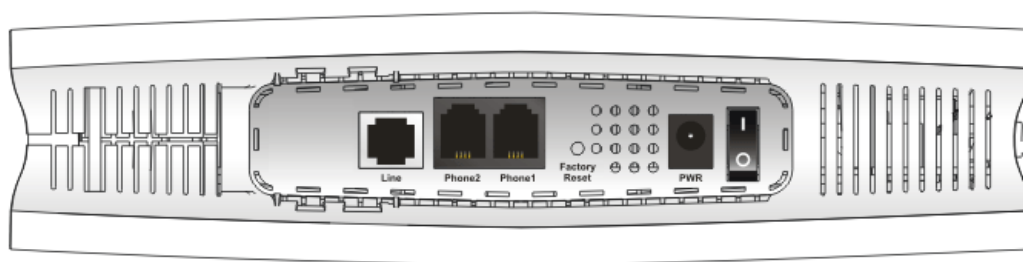

Interface	Description
Line	Connector for PSTN life line.
Phone2/Phone1	Connector of analog phone for VoIP communication.
Factory Reset	Restore the default settings. Usage: Turn on the router (ACT LED is blinking). Press the hole and keep for more than 5 seconds. When you see the ACT LED begins to blink rapidly than usual, release the button. Then the router will restart with the factory default configuration.
PWR	Connector for a power adapter.
ON/OFF	Power Switch.

1.1.4 For Vigor2710VDn

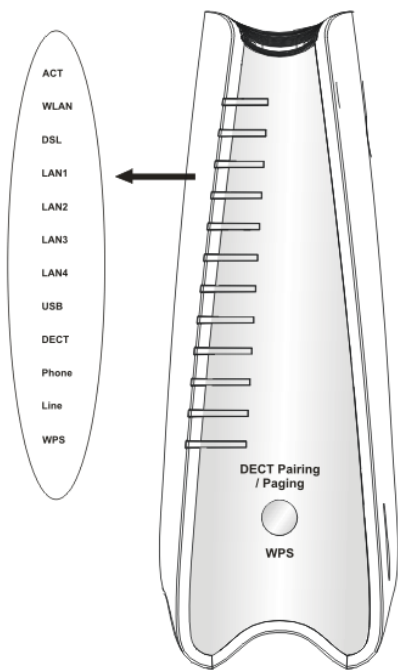

LED	Status	Explanation
ACT (Activity)	Blinking	The router is powered on and running normally.
	Off	The router is powered off.
WLAN	On	Wireless access point is ready.
	Blinking	It will blink while wireless traffic goes through.
DSL	On	The router is ready to access Internet through DSL link.
	Blinking	Slowly: The modem is ready. Quickly: The connection is training.
LAN 1/2/3/4	On	The port is connected.
	Off	The port is disconnected.
	Blinking	The data is transmitting.
USB	On	A USB device is connected and active.
	Blinking	The data is transmitting.
DECT	On	DECT phone is in use
	Off	DECT phone is idle or off.
	Blinking	A DECT phone call comes.
Phone	On	The phone connected to this port is off-hook.
	Off	The phone connected to this port is on-hook.
	Blinking	A phone call comes.
Line	On	A PSTN phone call comes (in and out). However, when the phone call is disconnected, the LED will be off about six seconds later.
	Off	There is no PSTN phone call.
WPS	On	The WPS is on.
	Off	The WPS is off.
	Blinking	Waiting for wireless client sending requests for connection or DECT handset about two minutes.
DECT Pairing/Paging / WPS Button	On	DECT Pairing and WPS: Press and hold the button for more than 2 seconds then you could try to register DECT phone with 2710 within 2 minutes. DECT Paging: Press once. All handsets will have beep sound, press the button again or press any key on any handset will stop the beep sound.
	Off	The WPS is off.
	Blinking	Waiting for wireless client sending requests for connection about 2 minutes.

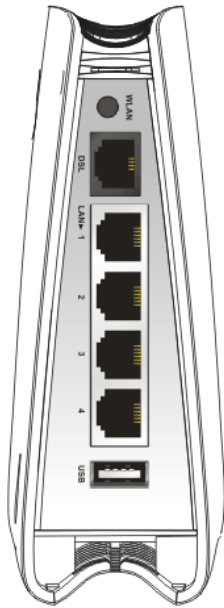

Interface	Description
WLAN	Press the button once to enable (WLAN LED on) or disable (WLAN LED off) wireless connection.
DSL	Connector for accessing the Internet through ADSL2/2+.
LAN (1-4)	Connectors for local networked devices.
USB	Connector for USB storage (Pen Driver/Mobile HD) or printer.

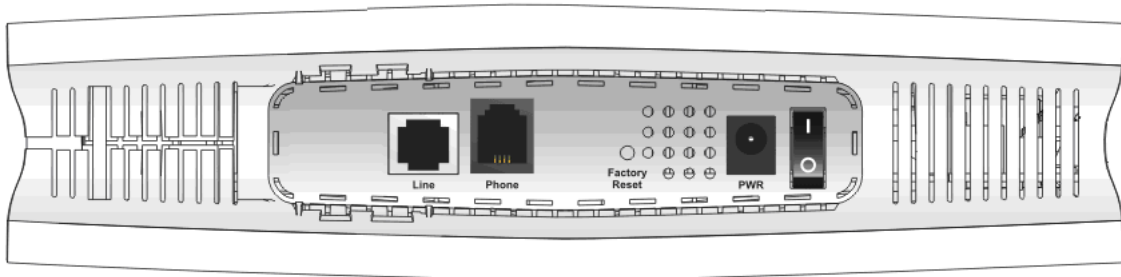

Interface	Description
Line	Connector for PSTN life line.
Phone	Connector of analog phone for VoIP communication.
Factory Reset	Restore the default settings. Usage: Turn on the router (ACT LED is blinking). Press the hole and keep for more than 5 seconds. When you see the ACT LED begins to blink rapidly than usual, release the button. Then the router will restart with the factory default configuration.
PWR	Connector for a power adapter.
ON/OFF	Power Switch.

1.2 Package Content



1 Quick Start Guide

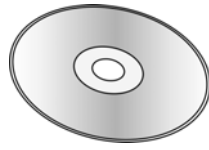

2 CD

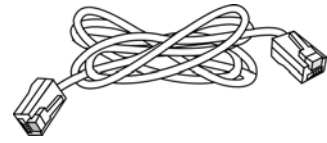

3 RJ-45 Cable (Ethernet)

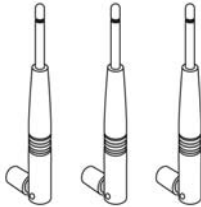

4 Antenna (n models)

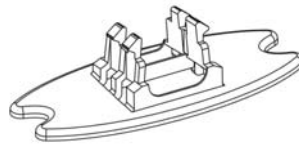

5 Stand

6 The type of the cable depends on the country that the router will be installed:



**RJ-11 to RJ-11 Cable
(Annex A)**

Or



**RJ-11 to RJ-45 Cable
(Annex B)**

Or



**RJ-45 to RJ-45 Cable
(Annex B)**

7 The type of the power adapter depends on the country that the router will be installed.

* The maximum power consumption is *17-23 Watt*.

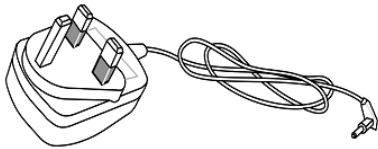

UK-type Power Adapter

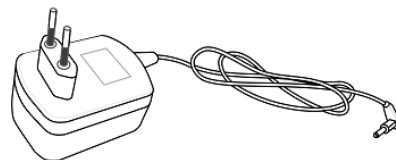

EU-type Power Adapter

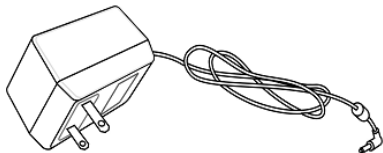

USA/Taiwan-type Power Adapter

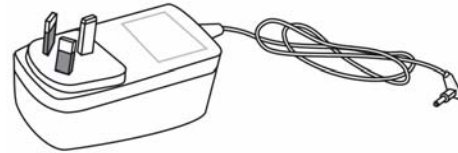

AU/NZ-type Power Adapter

2. Installing Your Router

This section will guide you to install the router through hardware connection and configure the router's settings through web browser.

2.1 Hardware Installation

Before starting to configure the router, you have to connect your devices correctly.

1. Connect the ADSL interface to the external ADSL splitter with an ADSL line cable for all models. For Vigor2710Vn/VDn, also connect Line interface to external ADSL splitter.

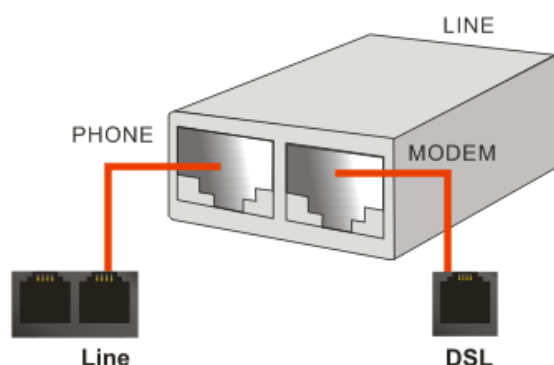

2. Connect one end of an Ethernet cable (RJ-45) to one of the **LAN** ports of the router and the other end of the cable (RJ-45) into the Ethernet port on your computer.
3. Connect the telephone sets with phone lines (for using VoIP function). For the model without phone ports, skip this step.
4. Connect one end of the power adapter to the router's power port on the rear panel, and the other side into a wall outlet.
5. Power on the device by pressing down the power switch.
6. The system starts to initiate. After completing the system test, the **ACT** LED will light up and start blinking.

Here, we take *Annex A* model as an example for describing hardware installation.

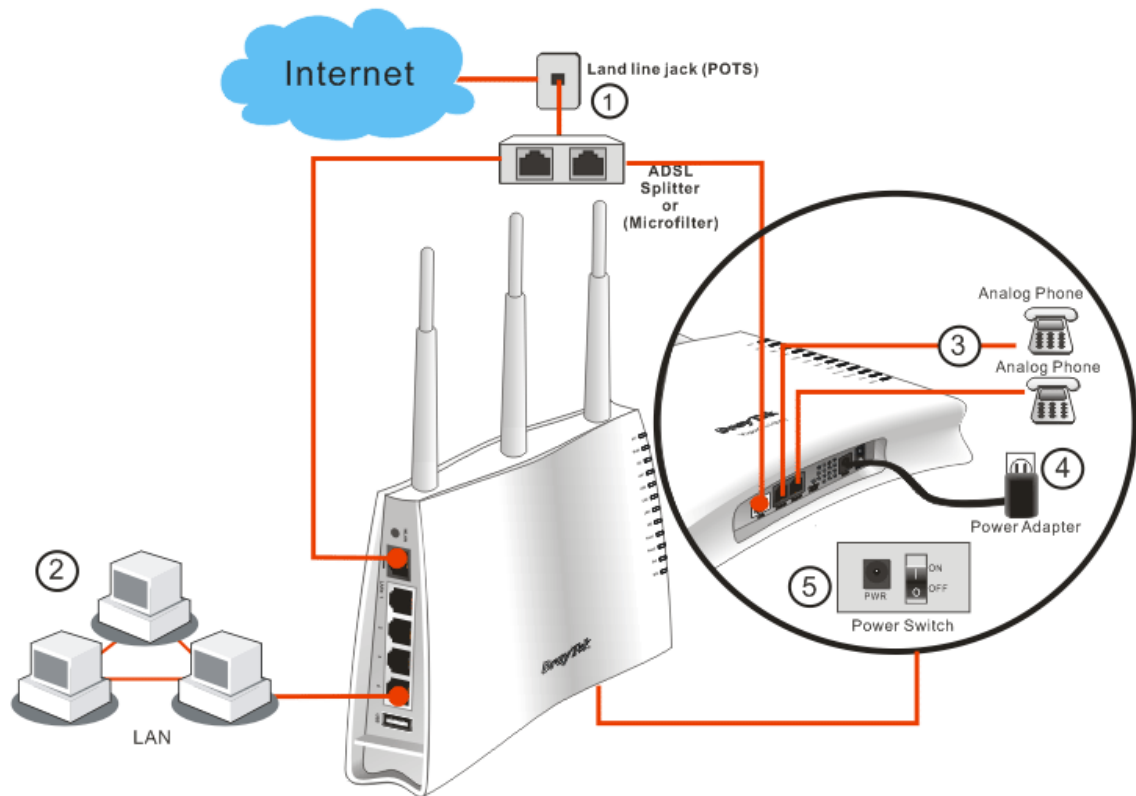

(For the detailed information of LED status, please refer to section 1.1.)

Caution:

1. Each of the Phone ports can be connected to an analog phone only. Do not connect the phone ports to the land line jack. Such connection might damage your router.
2. When the power is shutdown, VoIP phone will be disconnected. However, a phone set connected to Phone 2 port can be used as the traditional telephone for the line will be guided to land line jack via the router (loop through).

Stand Installation

The Vigor2710 series must be placed erectly. Therefore you have to install a stand onto the router to make it standing firmly. Please follow the figures listed below to finish the installation.

①

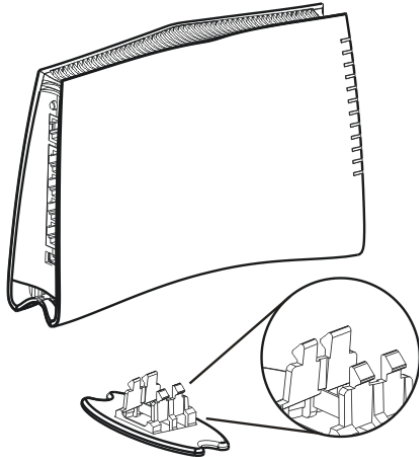

②

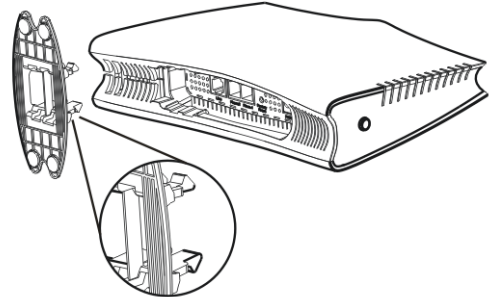

③

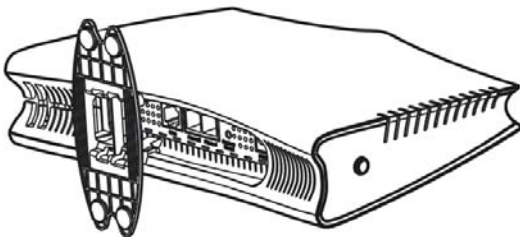

④

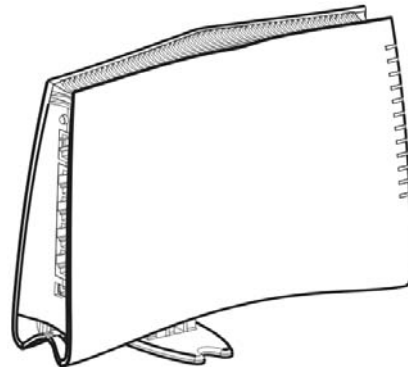

2.2 Printer Installation

You can install a printer onto the router for sharing printing. All the PCs connected this router can print documents via the router. The example provided here is made based on Windows XP/2000. For Windows 98/SE/Vista/7, please visit www.draytek.com.

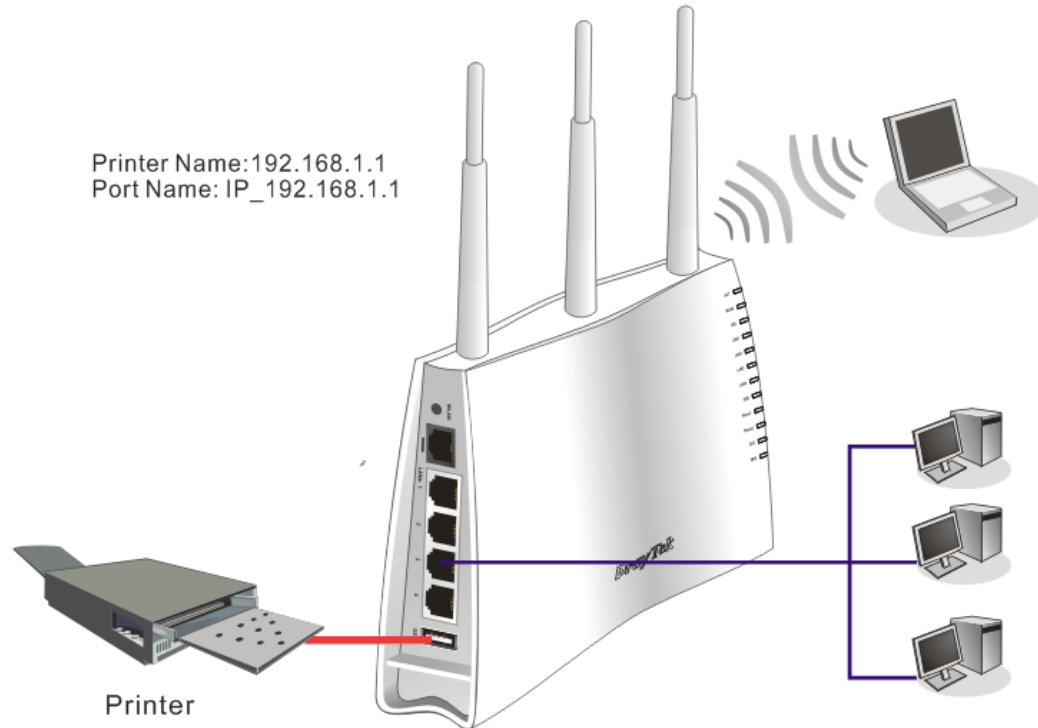

Before using it, please follow the steps below to configure settings for connected computers (or wireless clients).

1. Connect the printer with the router through USB port.
2. Open **Start->Settings-> Printer and Faxes**.

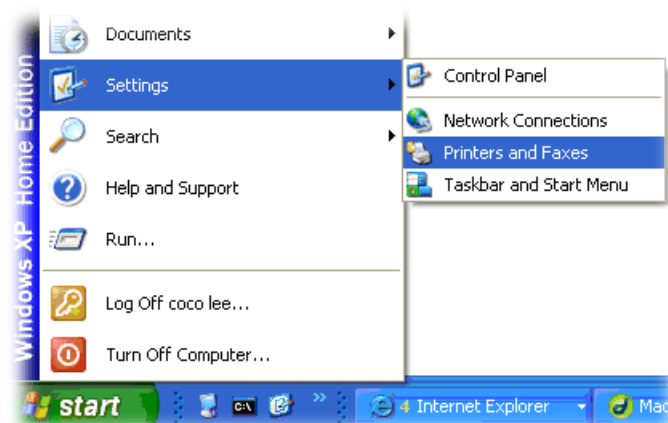

3. Open **File->Add a New Computer**. A welcome dialog will appear. Please click **Next**.

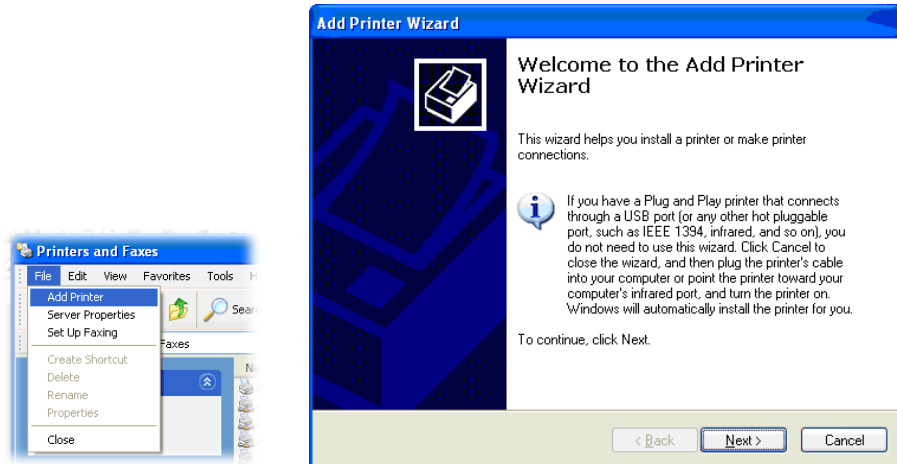

4. Click **Local printer attached to this computer** and click **Next**.

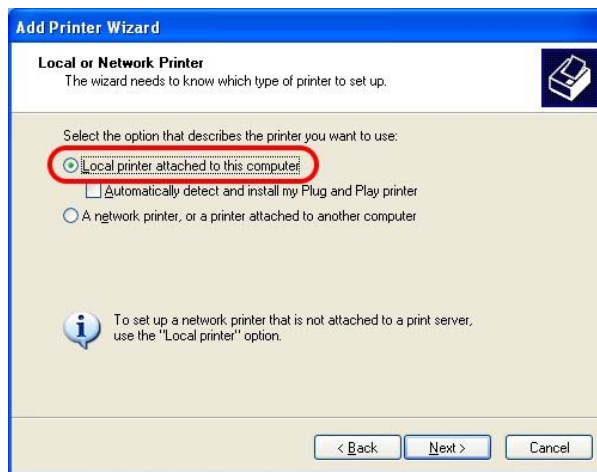

5. In this dialog, choose **Create a new port Type of port** and use the drop down list to select **Standard TCP/IP Port**. Click **Next**.

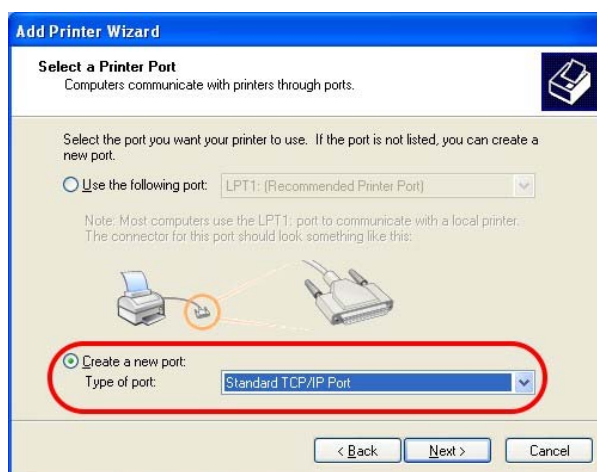

6. In the following dialog, type **192.168.1.1** (router's LAN IP) in the field of **Printer Name or IP Address** and type **IP_192.168.1.1** as the port name. Then, click **Next**.

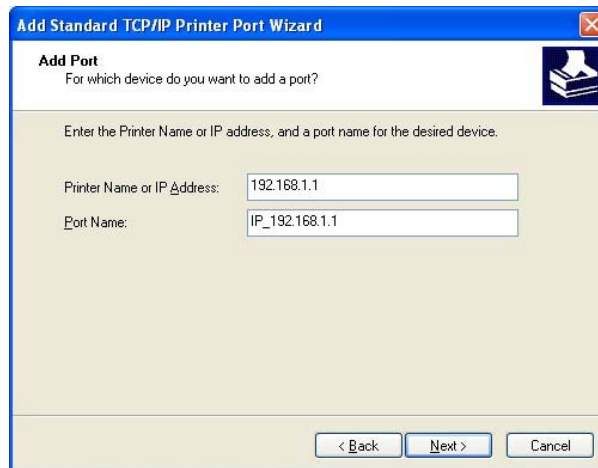

7. Click **Standard** and choose **Generic Network Card**.

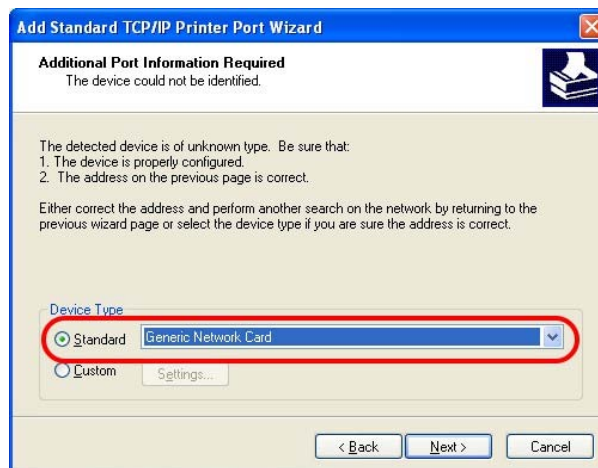

8. Then, in the following dialog, click **Finish**.



- Now, your system will ask you to choose right name of the printer that you installed onto the router. Such step can make correct driver loaded onto your PC. When you finish the selection, click **Next**.

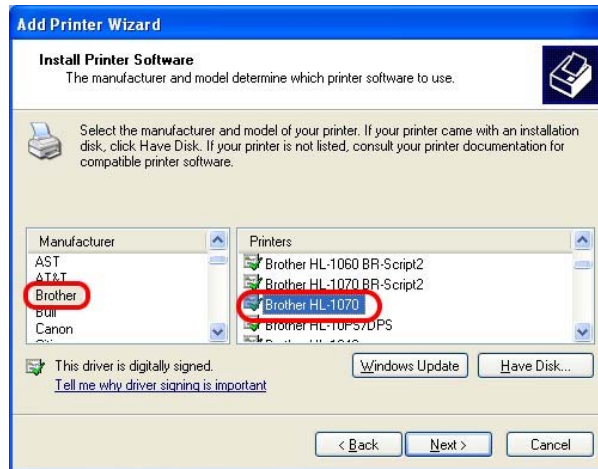

- For the final stage, you need to go back to **Control Panel-> Printers** and edit the property of the new printer you have added.

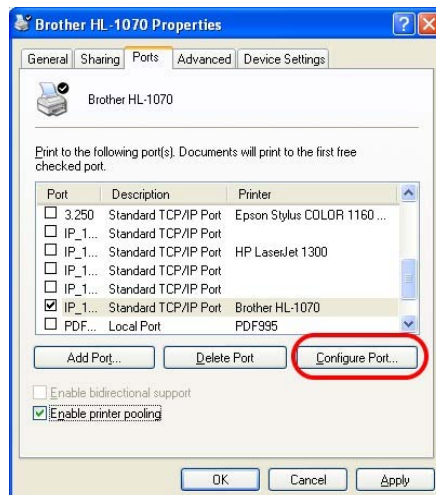

- Select "**LPR**" on Protocol, type **p1** (number 1) as Queue Name. Then click **OK**. Next please refer to the red rectangle for choosing the correct protocol and UPR name.

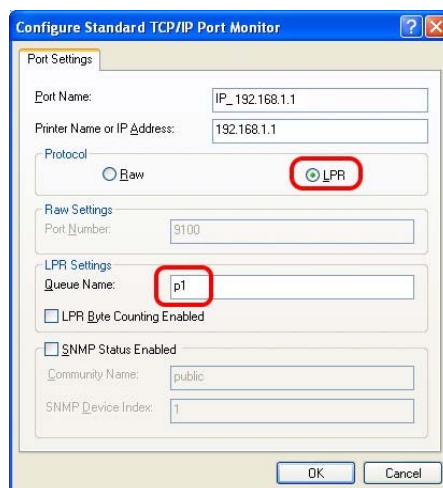

The printer can be used for printing now. Most of the printers with different manufacturers are compatible with vigor router.

Note 1: Some printers with the fax/scanning or other additional functions are not supported. If you do not know whether your printer is supported or not, please visit www.draytek.com to find out the printer list. Open **Support > FAQ/Application Notes**; find out the link of **Printer Server** and click it; then click the **What types of printers are compatible with Vigor router?** link.

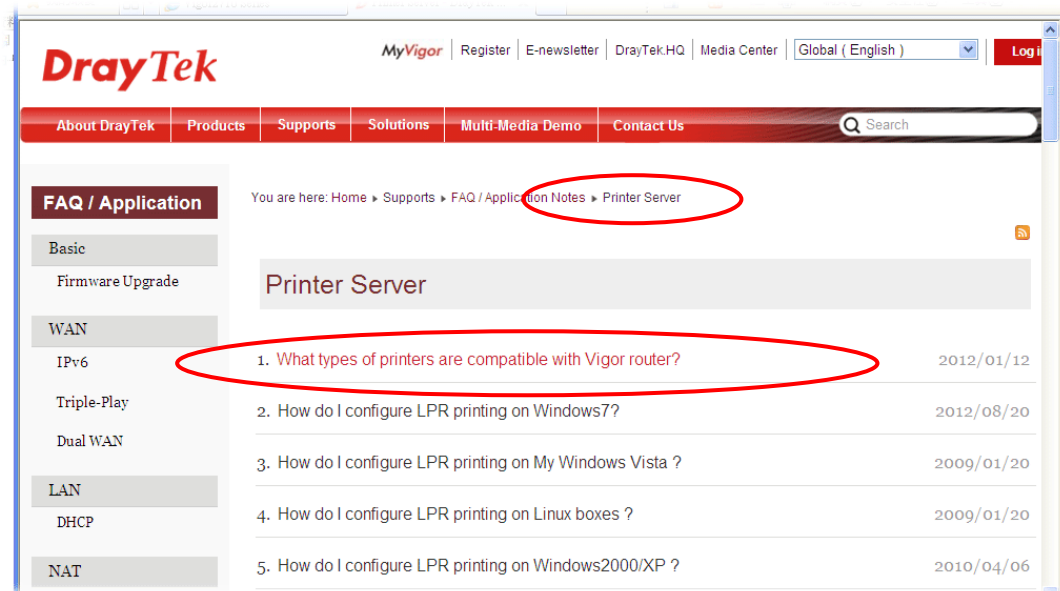

Note 2: Vigor router supports printing request from computers via LAN ports but not WAN port.

3. Configuring Web Pages

To access Internet, please finish basic configuration after completing the hardware installation.

3.1 Accessing Web Page

1. Make sure your PC connects to the router correctly.



Notice: You may either simply set up your computer to get IP dynamically from the router or set up the IP address of the computer to be the same subnet as **the default IP address of Vigor router 192.168.1.1**. For the detailed information, please refer to the later section - Trouble Shooting of the guide.

2. Open a web browser on your PC and type **http://192.168.1.1**. The following window will be open to ask for username and password.



3. Please type “admin/admin” as the Username/Password and click **Login**.



Notice: If you fail to access to the web configuration, please go to “Trouble Shooting” for detecting and solving your problem.

4. The web page can be logged out according to the chosen condition. The default setting is **Auto Logout**, which means the web configuration system will logout after five minutes without any operation. Change the setting for your necessity.

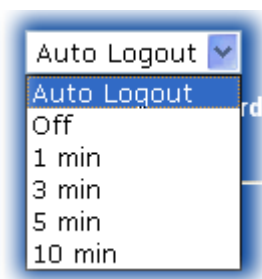

3.2 Basic Configuration

The **Quick Start Wizard** is designed for you to easily set up your router for Internet access. You can directly access the **Quick Start Wizard** via Web Configurator.

1. Open a web browser on your PC and type **http://192.168.1.1**. A pop-up window will open to ask for username and password.
2. Please type “admin/admin” as the Username/Password and click **Login**.
3. The **Main Screen** will appear. Click **Quick Start Wizard**.

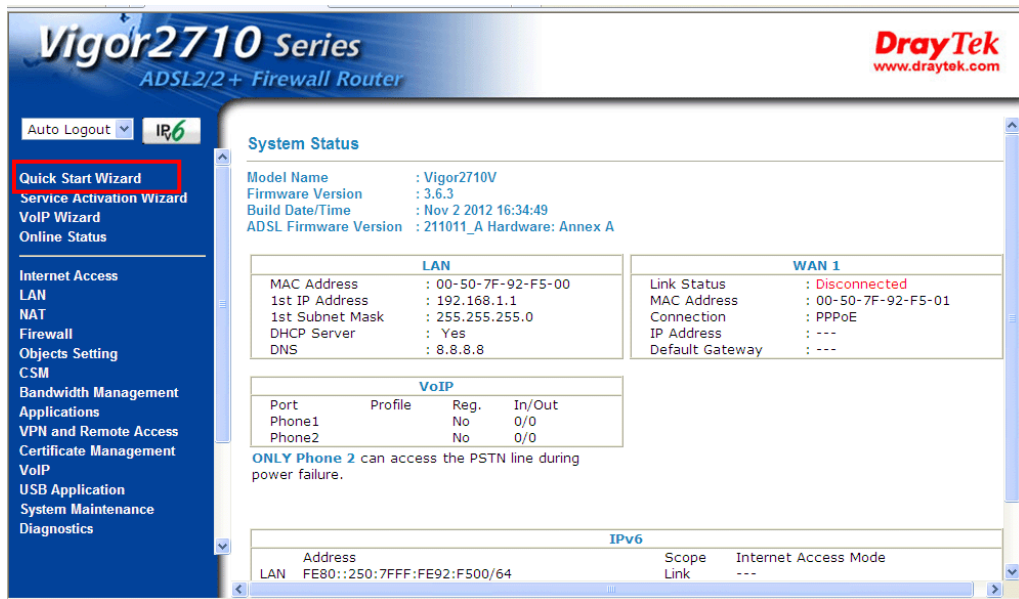

The screenshot displays the main configuration page for a Vigor2710 Series ADSL2/2+ Firewall Router. The left sidebar contains a menu with 'Quick Start Wizard' highlighted. The main content area shows system information and network settings.

LAN		WAN 1	
MAC Address	: 00-50-7F-92-F5-00	Link Status	: Disconnected
1st IP Address	: 192.168.1.1	MAC Address	: 00-50-7F-92-F5-01
1st Subnet Mask	: 255.255.255.0	Connection	: PPPoE
DHCP Server	: Yes	IP Address	: ---
DNS	: 8.8.8.8	Default Gateway	: ---

VoIP			
Port	Profile	Reg.	In/Out
Phone1		No	0/0
Phone2		No	0/0

ONLY Phone 2 can access the PSTN line during power failure.

IPv6		
Address	Scope	Internet Access Mode
LAN FE80::250:7FFF:FE92:F500/64	Link	---

Note: The home page will change slightly in accordance with the router you have.

4. Enter the old and new login passwords in the field of **Old Password** and **New Password** and retype the new one in the field of **Confirm Password**. Then click **Next** to continue. Next time, after restarting the router, new password must be typed for accessing into router web page.

Quick Start Wizard

Enter login password

Please enter an alpha-numeric string as your **Password** (Max 23 characters).

Old Password	<input type="password"/>
New Password	<input type="password"/>
Confirm Password	<input type="password"/>

- On the next page as shown below, please select the appropriate Internet access type **according to the information from your ISP**. For example, you should select PPPoE mode if the ISP provides you PPPoE interface. Then click **Next** for next step.

Quick Start Wizard

2. Connect to Internet

VPI	<input type="text" value="0"/>	<input type="button" value="Auto detect"/>
VCI	<input type="text" value="35"/>	
Protocol / Encapsulation	<input type="text" value="PPPoA VC MUX"/>	
Fixed IP	<input type="radio"/> Yes <input checked="" type="radio"/> No(Dynamic IP)	
IP Address	<input type="text"/>	
Subnet Mask	<input type="text"/>	
Default Gateway	<input type="text"/>	
Primary DNS	<input type="text"/>	
Second DNS	<input type="text"/>	

<input type="text" value="PPPoE LLC/SNAP"/>
<input type="text" value="PPPoE LLC/SNAP"/>
<input type="text" value="PPPoE VC MUX"/>
<input type="text" value="PPPoA LLC/SNAP"/>
<input type="text" value="PPPoA VC MUX"/>
<input type="text" value="1483 Bridged IP LLC"/>
<input type="text" value="1483 Routed IP LLC"/>
<input type="text" value="1483 Bridged IP VC-Mux"/>
<input type="text" value="1483 Routed IP VC-Mux (IPoA)"/>
<input type="text" value="1483 Bridged IP (IPoE)"/>

PPPoE/PPPoA: if you click PPPoE or PPPoA as the protocol, please manually enter the Username/Password provided by your ISP. Then click **Next**.

Quick Start Wizard

Set PPPoE / PPPoA

User Name	<input type="text" value="84005756@hinet.net"/>
Password	<input type="password" value="....."/>
Confirm Password	<input type="password" value="....."/>

1483 Bridged IP /1483 Routed IP: if you choose 1483 Bridged IP / 1483 Routed IP as the protocol, you will get the following page. Please type in the IP address information originally provided by your ISP. Then click **Next** for next step.

Quick Start Wizard

2. Connect to Internet

VPI	<input type="text" value="0"/>	<input type="button" value="Auto detect"/>
VCI	<input type="text" value="35"/>	
Protocol / Encapsulation	<input type="text" value="1483 Bridged IP LLC"/>	
Fixed IP	<input type="radio"/> Yes <input checked="" type="radio"/> No(Dynamic IP)	
IP Address	<input type="text"/>	
Subnet Mask	<input type="text"/>	
Default Gateway	<input type="text"/>	
Primary DNS	<input type="text"/>	
Second DNS	<input type="text"/>	

6. Now you can see the following screen. It indicates that the setup is complete. Different types of connection modes will have different summary. Click **Finish** and then restart the router. Afterward, you will enjoy surfing on the Internet.

Quick Start Wizard

Please confirm your settings:

VPI:	0
VCI:	33
Protocol / Encapsulation:	1483 Bridge LLC
Fixed IP:	No
Primary DNS:	
Secondary DNS:	

3.3 Wireless Configuration



For the user of Vigor2710, please skip this section.

For operating Vigor2710n/Vn/VDn well, it is necessary for you to set the wireless LAN settings for using wireless function. Please read the following paragraphs carefully for configuring the settings for this router.

3.3.1 Using WPS

In an Infrastructure Mode of wireless network, Vigor wireless router plays a role as an **Access Point (AP)** connecting to lots of wireless clients or Stations (STA). All the STAs (clients) will share the same Internet connection with other wired hosts via Vigor wireless router.

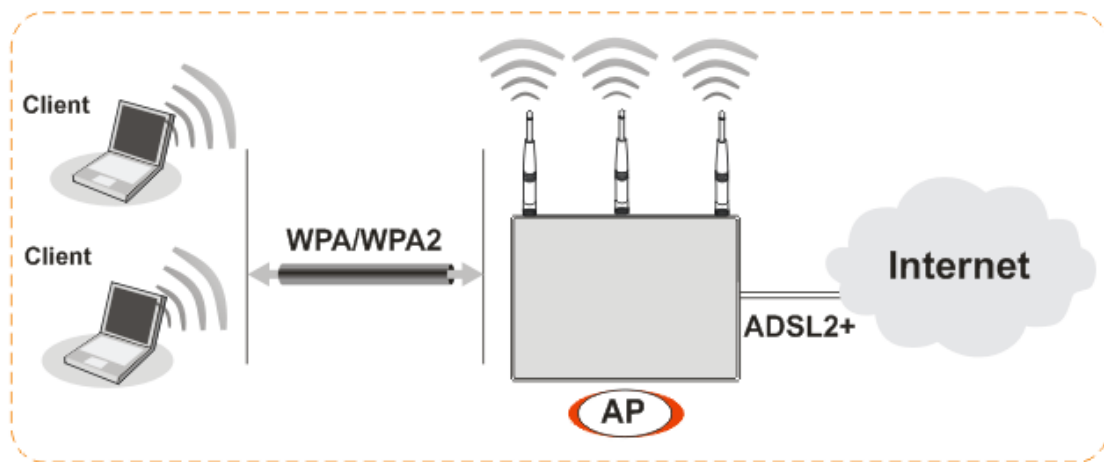

Vigor2710 provides you a **quick** method to access Internet through wireless connection. WPS (Wi-Fi Protected Setup) provides easy procedure to make network connection between wireless station and wireless access point (vigor router) with the encryption of WPA and WPA2.

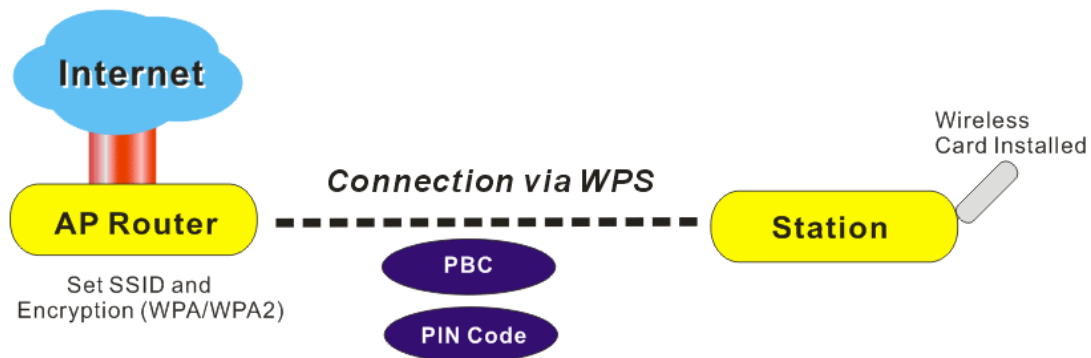

It is the simplest way to build connection between wireless network clients and vigor router. Users do not need to select any encryption mode and type any long encryption passphrase to setup a wireless client every time. He/she only needs to press a button on wireless client, and WPS will connect for client and router automatically.

There are two methods to do network connection through WPS between AP and Stations: pressing the **Start PBC** button or using **PIN Code**.

- On the side of Vigor 2710 series which served as an AP, press **WPS** button once on the front panel of the router or click **Start PBC** on web configuration interface. On the side of a station with network card installed, press **Start PBC** button of network card.

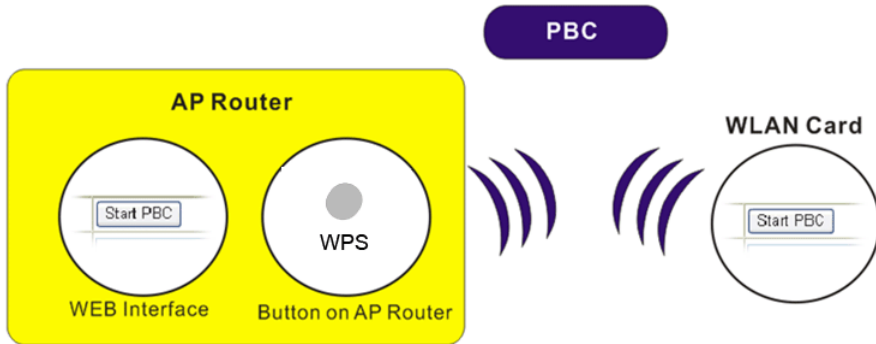

- If you want to use PIN code, you have to know the PIN code specified in wireless client. Then provide the PIN code of the wireless client you wish to connect to the vigor router.

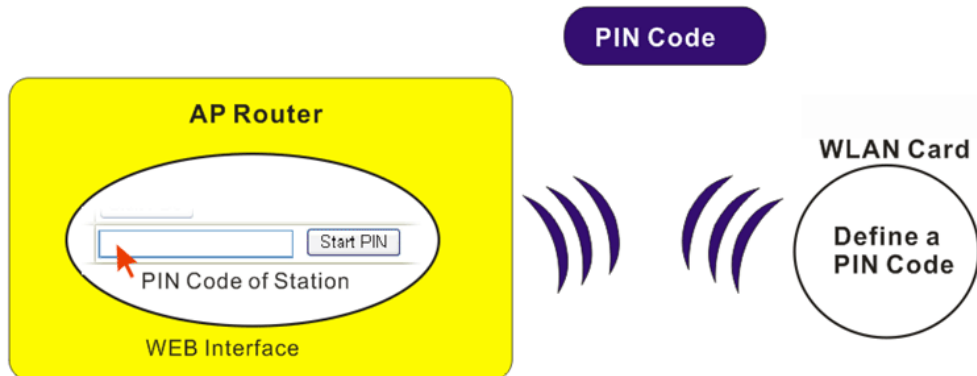

For WPS is supported in WPA-PSK or WPA2-PSK mode, if you do not choose such mode in **Wireless LAN>>Security**, you will see the following message box.

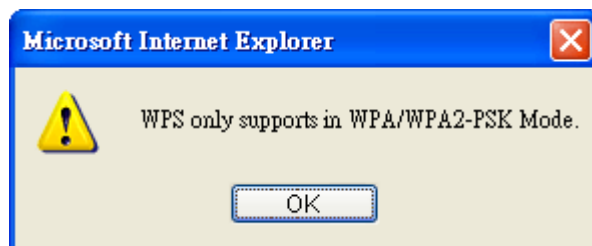

Please click **OK** and go back **Wireless LAN>>Security** to choose WPA-PSK or WPA2-PSK mode and access WPS again.

Below shows **Wireless LAN>>WPS** web page:

Wireless LAN >> WPS (Wi-Fi Protected Setup)

Enable WPS 

Wi-Fi Protected Setup Information

WPS Status	Configured
SSID	default
Authentication Mode	Disable

Device Configure

Configure via Push Button	<input type="button" value="Start PBC"/>
Configure via Client PinCode	<input type="text"/> <input type="button" value="Start PIN"/>

Status: The Authentication Mode is NOT WPA/WPA2 PSK!!

Note: WPS can help your wireless client automatically connect to the Access point.

 : WPS is Disabled.

 : WPS is Enabled.

 : Waiting for WPS requests from wireless clients.

1. Check **Enable WPS** to enable WPS setting.
2. Click **Start PBC** to invoke Push-Button style WPS setup procedure.
The router will wait for WPS requests from wireless clients about two minutes. The WPS LED on the router will blink fast when WPS is in progress. It will return to normal condition after two minutes. (You need to setup WPS within two minutes).
3. Please input the PIN code specified in wireless client you wish to connect, and click **Start PIN** button.
The WLAN LED on the router will blink fast when WPS is in progress. It will return to normal condition after two minutes. (You need to setup WPS within two minutes)

3.3.2 DECT Phone Connection (for VDn model only)

Vigor2710 provides a DECT phone resolution for users to utilize DECT phone for dialing VoIP/PSTN calls. Without the limitation of cable connection, ECT phone can be placed in any place in your house. People do not worry about being wiretapped for the content of the call will be encrypted and secure.

Vigor 2710 VDn provides a DECT GAP/CAT-iq base module, which can facilitate 4 simultaneous wireless audio connections and 6 phone registration.

1. Open **VoIP>>DECT**.

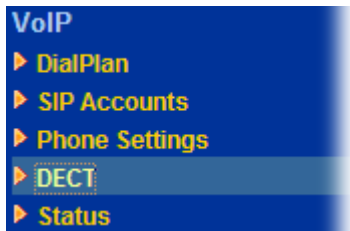

Note: DECT menu will appear if DECT module is detected..

2. In the web page, please click **Enable Registration Mode** and wait for DECT handset to register.

VoIP >> DECT

Handset Status

FwVersion: 0x101, LinkDate: 08.08.07.16.04, DectType: EU Dect

Handset	Status	PCM Channel	Deregister Handset
1	F00_REGISTERED_IDLE	255	<input type="button" value="Deregister"/>
2	HS_NOT_REGISTERED	255	<input type="button" value="Deregister"/>
3	HS_NOT_REGISTERED	255	<input type="button" value="Deregister"/>
4	HS_NOT_REGISTERED	255	<input type="button" value="Deregister"/>
5	HS_NOT_REGISTERED	255	<input type="button" value="Deregister"/>
6	HS_NOT_REGISTERED	255	<input type="button" value="Deregister"/>

Handset 1 is registered and idle. You could try to deregister by button.



: Waiting for DECT handset to register.

Enable DECT registration mode by this button or press DECT button for more than 2 seconds. This state could last for 2 minutes.

- When the registration is finished, open **VoIP>>SIP Accounts**. The Registered DECT phone will be available for you to choose. Choose the one you need.

VoIP >> SIP Accounts

Registered DECT handset could be chosen in DECT Ring Port.

SIP Accounts List Refresh

Index	Profile	Domain/Realm	Proxy	Account Name	Ring Port	Status
1				---	<input type="checkbox"/> Phone <input checked="" type="checkbox"/> DECT1 <input type="checkbox"/> DECT2 <input type="checkbox"/> DECT3 <input type="checkbox"/> DECT4 <input type="checkbox"/> DECT5 <input type="checkbox"/> DECT6	-
2				---	<input type="checkbox"/> Phone <input type="checkbox"/> DECT1 <input type="checkbox"/> DECT2 <input type="checkbox"/> DECT3 <input type="checkbox"/> DECT4 <input type="checkbox"/> DECT5 <input type="checkbox"/> DECT6	-
3				---	<input type="checkbox"/> Phone <input type="checkbox"/> DECT1 <input type="checkbox"/> DECT2 <input type="checkbox"/> DECT3 <input type="checkbox"/> DECT4	-

- Open **VoIP>>Status**. Information for the active DECT phone will be shown as follows.

VoIP >> Status

Status Refresh Seconds: 10

Port	Status	Codec	PeerID	Elapse (hh:mm:ss)	Tx Pkts	Rx Pkts	Rx Losts	Rx Jitter (ms)	In Calls	Out Calls	Miss Calls	Speaker Gain
Phone	IDLE			00:00:00	0	0	0	0	0	0	0	5
DECT1	IDLE			00:00:00	0	0	0	0	0	0	0	5
DECT2	IDLE			00:00:00	0	0	0	0	0	0	0	5
DECT3	IDLE			00:00:00	0	0	0	0	0	0	0	5
DECT4	IDLE			00:00:00	0	0	0	0	0	0	0	5
DECT5	ACTIVE	729A/B	1@192.168.1.2	00:00:14	414	414	0	0	0	2	0	5
DECT6	IDLE			00:00:00	0	0	0	0	0	0	0	5

If voip connection is established, you could monitor the status in this page.

When registering with DECT phone, you will be asked to type access code. The default setting in Vigor2710VDn is **1234**. Please open **VoIP>>Phone Settings** to modify it if required.

3	DECT2		G.729A/B	User Defined	5/5		InBand
4	DECT3		G.729A/B	User Defined	5/5		InBand
5	DECT4		G.729A/B	User Defined	5/5		InBand
6	DECT5		G.729A/B	User Defined	5/5		InBand
7	DECT6		G.729A/B	User Defined	5/5		InBand

Disable Port: Phone

Note: If Phone port is disabled, Phone could not be used anymore. However, its dsp resource could be used by DECT and DECT could dial 4 voip call at the same time. Otherwise, DECT could only dial 3 voip call at the same time.

DECT phone access code :

Note: Default DECT phone access code is 1234.

Setup DECT phone access code here. Default value is 1234.

The following diagram shows the brief construction of DECT phone (handset) and Vigor router.

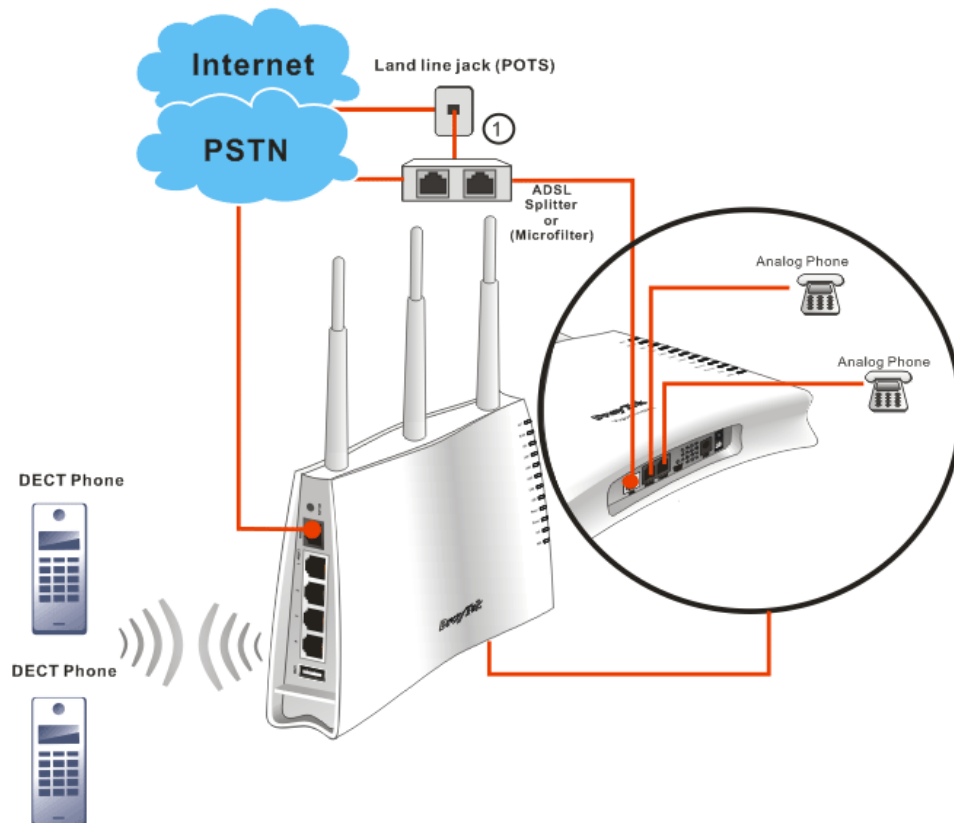

4. Trouble Shooting

This section will guide you to solve abnormal situations if you cannot access into the Internet after installing the router and finishing the web configuration. Please follow sections below to check your basic installation status stage by stage.

- Checking if the hardware status is OK or not.
- Checking if the network connection settings on your computer are OK or not.
- Pinging the router from your computer.
- Checking if the ISP settings are OK or not.
- Backing to factory default setting if necessary.

If all above stages are done and the router still cannot run normally, it is the time for you to contact your dealer for advanced help.

4.1 Checking If the Hardware Status Is OK or Not

Follow the steps below to verify the hardware status.

1. Check the power line and LAN cable connections. Refer to “**2.1 Hardware Installation**” for details.
2. Turn on the router. Make sure the **ACT LED** blink once per second and the correspondent **LAN LED** is bright.

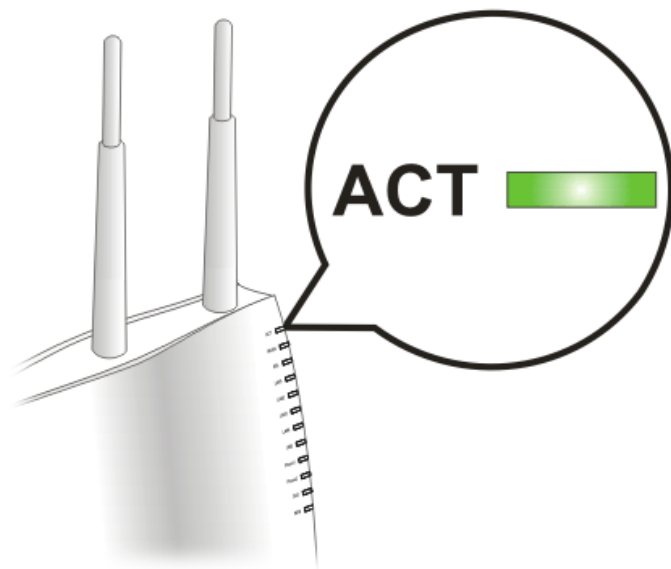

3. If not, it means that there is something wrong with the hardware status. Simply back to “**2.1 Hardware Installation**” to execute the hardware installation again. And then, try again.

4.2 Checking If the Network Connection Settings on Your Computer Is OK or Not

Sometimes the link failure occurs due to the wrong network connection settings. After trying the above section, if the link is still failed, please do the steps listed below to make sure the network connection settings is OK.

For Windows



The example is based on Windows XP. As to the examples for other operation systems, please refer to the similar steps or find support notes in www.draytek.com.

1. Go to **Control Panel** and then double-click on **Network Connections**.



2. Right-click on **Local Area Connection** and click on **Properties**.

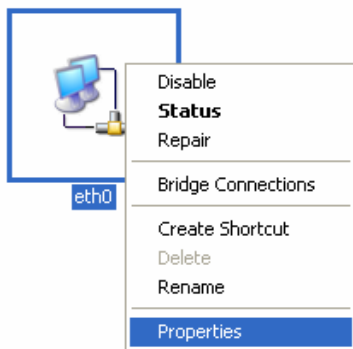

3. Select **Internet Protocol (TCP/IP)** and then click **Properties**.

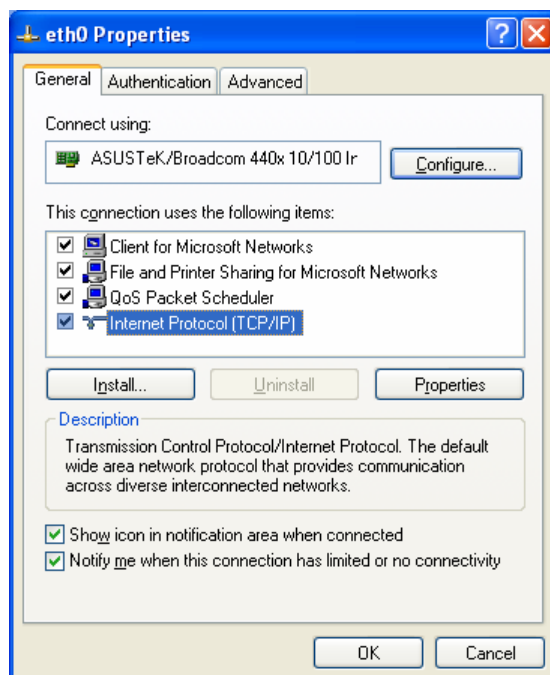

4. Select **Obtain an IP address automatically** and **Obtain DNS server address automatically**.

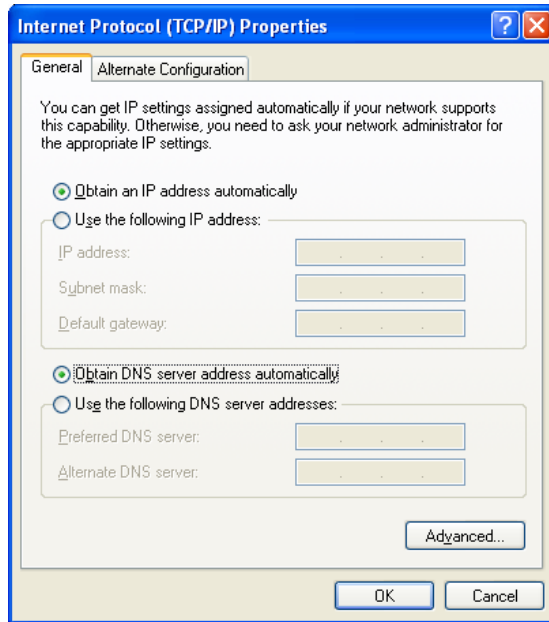

For Mac OS

1. Double click on the current used Mac OS on the desktop.
2. Open the **Application** folder and get into **Network**.
3. On the **Network** screen, select **Using DHCP** from the drop down list of Configure IPv4.

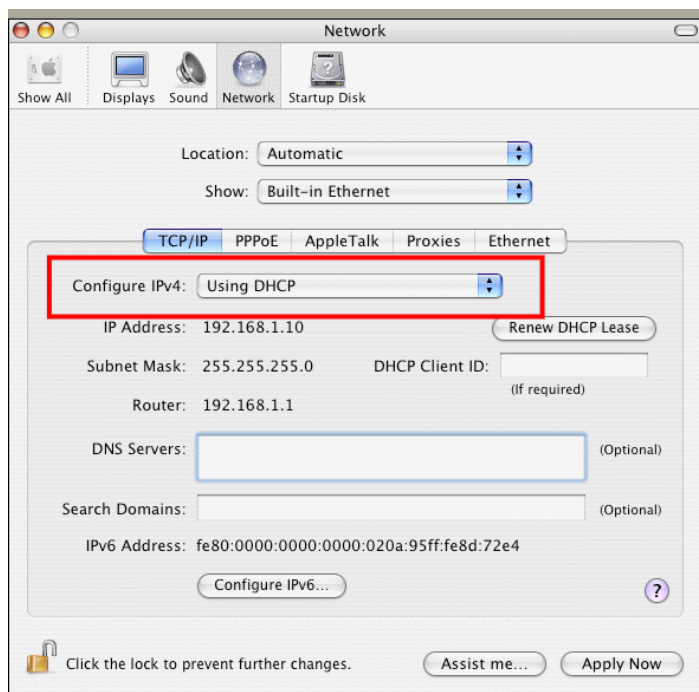

4.3 Pinging the Router from Your Computer

The default gateway IP address of the router is 192.168.1.1. For some reason, you might need to use “ping” command to check the link status of the router. **The most important thing is that the computer will receive a reply from 192.168.1.1.** If not, please check the IP address of your computer. We suggest you setting the network connection as **get IP automatically**. (Please refer to the section 4.2)

Please follow the steps below to ping the router correctly.

For Windows

1. Open the **Command Prompt** window (from **Start menu> Run**).
2. Type **command** (for Windows 95/98/ME) or **cmd** (for Windows NT/2000/XP/Vista/7). The DOS command dialog will appear.

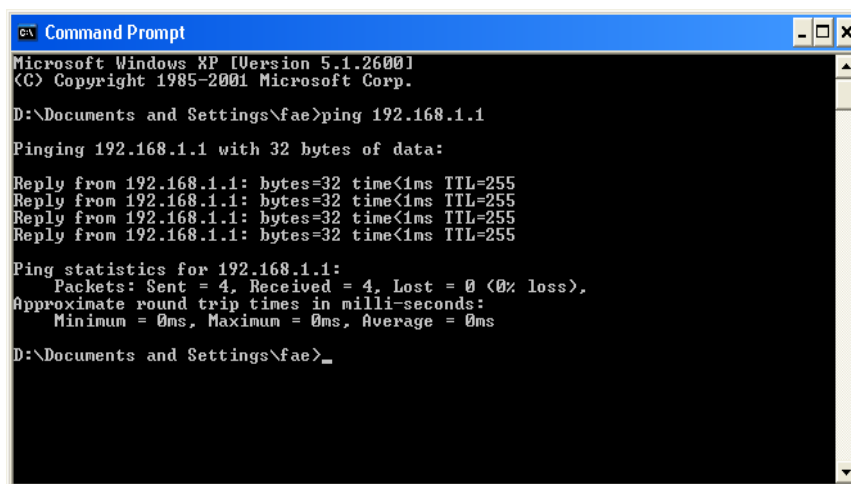

```
Command Prompt
Microsoft Windows XP [Version 5.1.2600]
(C) Copyright 1985-2001 Microsoft Corp.

D:\Documents and Settings\fae>ping 192.168.1.1

Pinging 192.168.1.1 with 32 bytes of data:

Reply from 192.168.1.1: bytes=32 time<1ms TTL=255
Reply from 192.168.1.1: bytes=32 time<1ms TTL=255
Reply from 192.168.1.1: bytes=32 time<1ms TTL=255
Reply from 192.168.1.1: bytes=32 time<1ms TTL=255

Ping statistics for 192.168.1.1:
    Packets: Sent = 4, Received = 4, Lost = 0 (0% loss),
    Approximate round trip times in milli-seconds:
        Minimum = 0ms, Maximum = 0ms, Average = 0ms

D:\Documents and Settings\fae>_
```

3. Type **ping 192.168.1.1** and press [Enter]. If the link is OK, the line of “**Reply from 192.168.1.1:bytes=32 time<1ms TTL=255**” will appear.
4. If the line does not appear, please check the IP address setting of your computer.

For Mac OS (Terminal)

1. Double click on the current used Mac OS on the desktop.
2. Open the **Application** folder and get into **Utilities**.
3. Double click **Terminal**. The Terminal window will appear.
4. Type **ping 192.168.1.1** and press [Enter]. If the link is OK, the line of “**64 bytes from 192.168.1.1: icmp_seq=0 ttl=255 time=xxxx ms**” will appear.



```

Terminal — bash — 80x24
Last login: Sat Jan 3 02:24:18 on ttty1
Welcome to Darwin!
Vigor10:~ draytek$ ping 192.168.1.1
PING 192.168.1.1 (192.168.1.1): 56 data bytes
64 bytes from 192.168.1.1: icmp_seq=0 ttl=255 time=0.755 ms
64 bytes from 192.168.1.1: icmp_seq=1 ttl=255 time=0.697 ms
64 bytes from 192.168.1.1: icmp_seq=2 ttl=255 time=0.716 ms
64 bytes from 192.168.1.1: icmp_seq=3 ttl=255 time=0.731 ms
64 bytes from 192.168.1.1: icmp_seq=4 ttl=255 time=0.72 ms
^C
--- 192.168.1.1 ping statistics ---
5 packets transmitted, 5 packets received, 0% packet loss
round-trip min/avg/max = 0.697/0.723/0.755 ms
Vigor10:~ draytek$ █

```

4.4 Checking If the ISP Settings are OK or Not

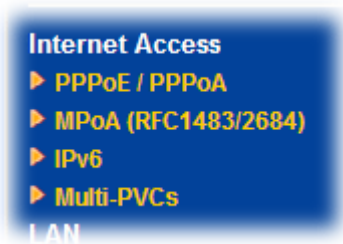
Open **Internet Access** page and then check whether the ISP settings are set correctly. Click PPPoE/PPPoA/MPoA/Multi-PVCs link to review the settings that you configured previously.



Take PPPoE User as an Example

1. Check if the **Enable** option is selected.
2. Check if **Username** and **Password** are entered with correct values that you **got from your ISP**.

Internet Access >> PPPoE / PPPoA

PPPoE / PPPoA Client Mode

PPPoE/PPPoA Client Enable Disable

DSL Modem Settings

Multi-PVC channel: Channel 1

VPI: 0

VCI: 33

Encapsulating Type: LLC/SNAP

Protocol: PPPoE

Modulation: Multimode

PPPoE Pass-through

For Wired LAN

Note: If this box is checked while using the PPPoA protocol, the router will behave like a modem which only serves the PPPoE client on the LAN.

ISP Access Setup

ISP Name:

Username:

Password:

PPP Authentication: PAP or CHAP

Always On

Idle Timeout: -1 second(s)

IP Address From ISP

Fixed IP Yes No (Dynamic IP)

Fixed IP Address:

Default MAC Address

Specify a MAC Address

MAC Address:

4.5 Problems for 3G Network Connection

When you have trouble in using 3G network transmission, please check the following:

Check if USB LED lights on or off

You have to wait about 15 seconds after inserting 3G USB Modem into your Vigor2710. Later, the USB LED will light on which means the installation of USB Modem is successful. If the USB LED does not light on, please remove and reinsert the modem again. If it still fails, restart Vigor2710.

USB LED lights on but the network connection does not work

Check the PIN Code of SIM card is disabled or not. Please use the utility of 3G USB Modem to disable PIN code and try again. If it still fails, it might be the compliance problem of system. Please open DrayTek Syslog Tool to capture the connection information (WAN Log) and send the page (similar to the following graphic) to the service center of DrayTek.

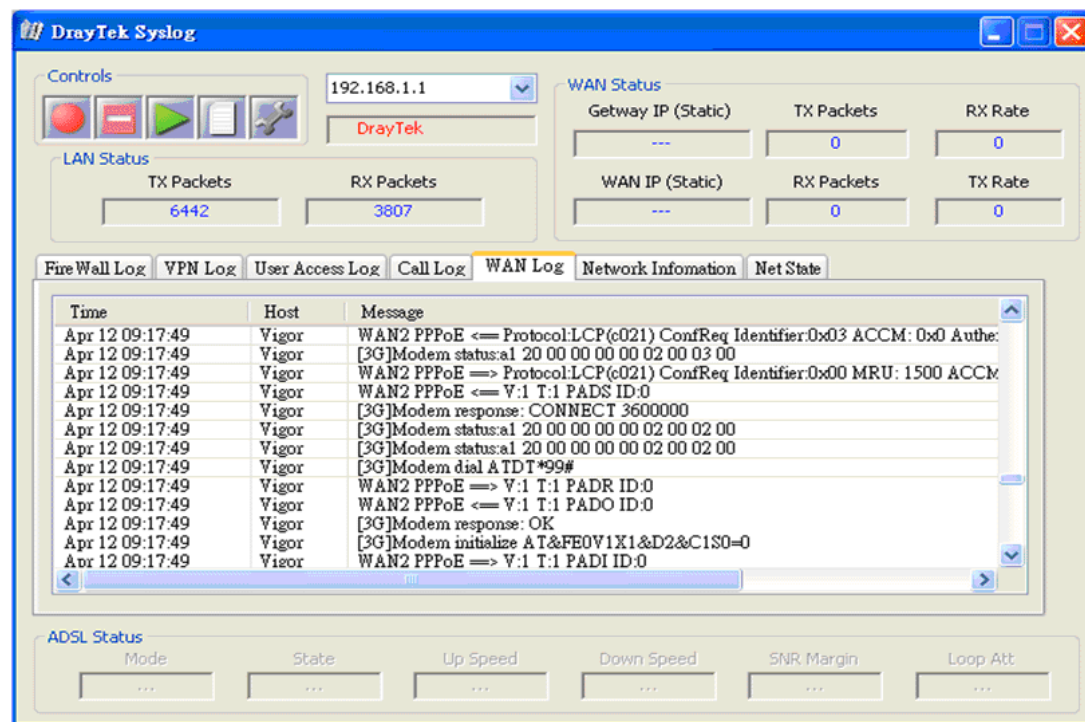

Transmission Rate is not fast enough

Please connect your Notebook with 3G USB Modem to test the connection speed to verify if the problem is caused by Vigor2710. In addition, please refer to the manual of 3G USB Modem for LED Status to make sure if the modem connects to Internet via HSDPA mode. If you want to use the modem indoors, please put it on the place near the window to obtain better signal receiving.

4.6 Backing to Factory Default Setting If Necessary

Sometimes, a wrong connection can be improved by returning to the default settings. Try to reset the router by software or hardware.



Warning: After pressing **factory default setting**, you will lose all settings you did before. Make sure you have recorded all useful settings before you pressing. The password of factory default is null.

Software Reset

You can reset the router to factory default via Web page via administrator's operation.

Go to **System Maintenance** and choose **Reboot System** on the web page. The following screen will appear. Choose **Using factory default configuration** and click **Reboot Now**. After few seconds, the router will return all the settings to the factory settings.

[System Maintenance >> Reboot System](#)

Reboot System

Do you want to reboot your router ?

- Using current configuration
- Using factory default configuration

Reboot Now

Auto Reboot Time Schedule

Index(1-15) in [Schedule](#) Setup: , , ,

Note: Action and Idle Timeout settings will be ignored.

OK

Cancel

Hardware Reset

While the router is running (ACT LED blinking), press the **Factory Reset** button and hold for more than 5 seconds. When you see the **ACT LED** blinks rapidly, please release the button. Then, the router will restart with the default configuration.

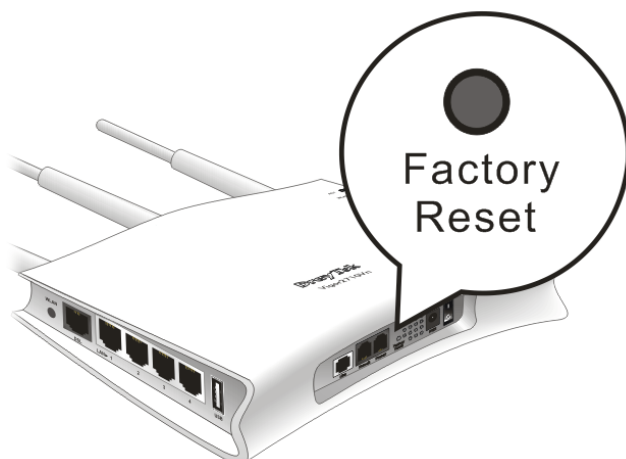

After restore the factory default setting, you can configure the settings for the router again to fit your personal request.

4.7 Contacting Your Dealer

If the router still cannot work correctly after trying many efforts, please contact your dealer for further help right away. For any questions, please feel free to send e-mail to support@draytek.com.